

# On-Line Maintenance of Simplified Weighted Graphs for Efficient Distance Queries

Floris Geerts  
University of Edinburgh  
Hasselt University  
fgeerts@inf.ed.ac.uk

Peter Revesz  
University of Nebraska-Lincoln  
Max Planck Inst. für Informatik  
revesz@cse.unl.edu

Jan Van den Bussche  
Hasselt University  
Transnational Univ. of Limburg  
jan.vandenbussche@uhasselt.be

## Abstract

We give two efficient on-line algorithms to simplify weighted graphs by eliminating degree-two vertices. Our algorithms are on-line — they react to updates on the data, keeping the simplification up-to-date. We provide both analytical and empirical evaluations of the efficiency of our algorithms. We prove an  $O(\log n)$  upper bound on the amortized time complexity of our maintenance algorithms, with  $n$  the number of insertions. One of our algorithms can handle in logarithmic time the deletions of vertices and edges as well.

**Categories and Subject Descriptors:** E.1: Graphs and networks

**General Terms:** Algorithms.

**Keywords:** topological simplification, network graph algorithms, online algorithms.

## 1. Introduction

Many real-life applications involve data in the form of some network, such as a road, railway, or river network. It is common to represent such network data by an undirected weighted graph, where the weights represent distance information. Many applications, such as on-line monitoring involve traffic jams in road networks or downlinks in computer networks, require efficiently answering a series of shortest path queries about the network, which changes dynamically by insertions and deletions of nodes and edges.

In developing efficient algorithms, we adopt the idea of “topological simplification” first proposed for only unweighted graphs by [7, 10, 11] to weighted graphs. In a topological simplification, all “regular vertices”, i.e., vertices that are adjacent to exactly two edges, are removed to form new edges between vertices of degree one or degree greater than two.

We extend this simplification by making the weight of the new edge from vertex  $A$  to vertex  $B$  to be the sum of the weights of the small edges that lead from  $A$  to  $B$  via only regular vertices. Whether this simplification trick will work or not, depends on two factors. First, the percentage of regular

vertices in a typical network. Second, the maintenance cost of the simplification. We don't need to worry much about the first factor, because many studies have shown that the percentage of regular vertices is large in typical networks [14].

The second factor is the more interesting issue. Answering queries using the simplified network instead of the original one, requires on-line maintenance of the simplified network under updates to the original one. Hence the update should be doable with a minimal overhead. The present paper proposes two different algorithms for on-line maintenance of “topologically simplified” weighted undirected graphs.

**Topology Tree Algorithm:** This is based on the topology tree of [2] and has  $O(n \log(n))$  time complexity.

**Renumbering Algorithm:** This algorithm relies on the numbering and renumbering of the regular vertices and takes on average *logarithmic* time per edge insertion.

Unlike most GIS data structures, e.g., an ARC/INFO planar map structure, both algorithms allow a non-planar data structure. Real-life network data is often *not* planar (e.g., in a road or railway network, where bridges occur).

Our algorithms are efficient in insertions (of vertices and edges), but not in deletions. For applications requiring also deletions, the Topology Tree Algorithm can be easily extended to efficiently handle those too. The Renumbering Algorithm can be also extended to handle deletions but not very efficiently. However, the Renumbering Algorithm should not be dismissed, because in many real-life applications insertions are sufficient; and, as our empirical comparisons show, for these types of applications the Renumbering Algorithm can be significantly faster than the Topological Tree Algorithm.

Many details which had to be omitted here due to space limitations can be found in our full technical report [5].

## 2. Basic Definitions

In undirected graph  $G = (V, E, \lambda)$  without self-loops and with edge-weights given by mapping  $\lambda : E \rightarrow \mathbf{R}^+$ , we say:

1. A vertex  $v$  is *regular* if and only if it is adjacent to precisely two edges.
2. A vertex that is not regular is called *singular*.
3. A path between two singular vertices that passes only through regular vertices is called a *regular path*.

We assume that the graph  $G$  does not contain regular cycles, i.e., cycles consisting of regular vertices only. The

Permission to make digital or hard copies of all or part of this work for personal or classroom use is granted without fee provided that copies are not made or distributed for profit or commercial advantage and that copies bear this notice and the full citation on the first page. To copy otherwise, to republish, to post on servers or to redistribute to lists, requires prior specific permission and/or a fee.

ACM-GIS'06, November 10–11, 2006, Arlington, Virginia, USA.  
Copyright 2006 ACM 1-59593-529-0/06/0011 ...\$5.00.

simplification  $G_s = (V_s, E_s, \lambda_s)$  of  $G$  is a multigraph with self-loops and weighted edges, which is obtained as follows:

1.  $V_s$ , the set of nodes of  $G_s$ , consists of all singular vertices of  $G$ .
2.  $E_s$ , the set of edges of  $G_s$ , formally consists of all regular paths of  $G$ . Every regular path between two singular vertices  $v$  and  $w$  represents a *topological edge* in  $G_s$  between  $v$  and  $w$ . There might be multiple regular paths between two singular vertices, hence in general  $G_s$  is a multigraph.
3. the weight  $\lambda_s(e)$  of a topological edge  $e$  is equal to the sum of all weights of edges on the regular path corresponding to  $e$ .

When a particular regular path  $e$  between two singular vertices  $v$  and  $w$  is clear from the context, we will conveniently denote the topological edge  $e$  by  $\{v, w\}$ .

### 3. Online Simplification in General

We consider only insertions of a new isolated vertex and insertions of edges between existing vertices in the graph  $G$  (other more complex insertion operations can be translated into a sequence of these basic insertion operations). The insertion of an isolated vertex is handled trivially, i.e., we insert it into  $V_s$ .

For the insertion of an edge we distinguish among six cases.

1. Vertices  $x$  and  $y$  are singular and  $\deg(x) \neq 1 \neq \deg(y)$ .
2. Vertices  $x$  and  $y$  are singular and one of them, say  $x$ , has degree one.
3. Vertices  $x$  and  $y$  are singular and  $\deg(x) = \deg(y) = 1$ .
4. One of the vertices  $x$  and  $y$  is regular, say  $x$ , and the other vertex,  $y$ , is singular and has degree one.
5. One of the vertices, say  $x$ , is regular and the other one,  $y$ , is singular with degree not equal to one.
6. Both  $x$  and  $y$  are regular.

As an example, Figure 1 shows case 6. The left side of shows the situation before the insertion of the edge  $\{x, y\}$ , drawn as the dotted line, and the right side shows the situation after the insertion. The topological edges are drawn in thick lines. The other cases can be handled similarly.

If no regular vertices are involved, then the update on the graph  $G$  translates in a straightforward way to an update on the simplification  $G_s$ . It is only in cases 4, 5, and 6, that the update on the graph  $G$  involves vertices which *have no counterpart* in the simplification  $G_s$ . In these cases, we need to find the edge to split and the weights of the topological edges created by the split. Consequently, the problem of maintaining the simplification  $G_s$  of a graph  $G$  amounts to two tasks:

- Maintain a function *find topological edge*, which takes a regular vertex as input, and outputs the topological edge whose corresponding regular path in  $G$  contains the input vertex.
- Maintain a function *find weights* which outputs the weights of the edges created when a topological edge is split at the input vertex.

## 4. Topology Tree Algorithm

We now introduce an algorithm for keeping the simplification of a graph up-to-date when this graph is subject to edge insertions. We only describe the case of edge insertion, but it is straightforward to extend the Topology Tree Algorithm to a fully dynamic algorithm, which can also react to deletions. The algorithm uses a direct adaptation of the topology-tree data structure of Frederickson [2, 3]. This data structure has been used extensively in other partially and fully dynamic algorithms [6]. We first show how the topological edge can be found efficiently.

### 4.1 Regular multilevel partition

We define a *cluster* as a set of vertices. The *size* of a cluster is the number of vertices it contains. A *regular cluster* is a cluster of size at most two, containing adjacent regular vertices. A *regular partition* of a graph  $G$  is a partition of the set  $V_r$  of regular vertices, such that for any two adjacent regular vertices  $v$  and  $w$ , the following holds:

- either  $v$  and  $w$  are in the same regular cluster  $C$ ; or
- $v$  and  $w$  are in different regular clusters  $C_v$  and  $C_w$ , and at least one of these regular clusters has size two.

A *regular multilevel partition* of a graph  $G$  is a set of partitions of  $V_r$  that satisfy the following (see Figure 2):

1. For each level  $i = 0, 1, \dots, k$ , the clusters at level  $i$  form a partition of  $V_r$ .
2. The clusters at level 0 form a regular partition of  $V_r$ .
3. The clusters at level  $i$  form a regular partition when viewing each cluster at level  $i - 1$  as a regular vertex.

A *regular forest* of a graph  $G$  is a forest based on a regular multilevel partition of  $G$ . We focus on the construction of a single tree in the forest corresponding to a single regular path. A single tree is constructed as follows (see Figure 3).

1. A vertex at level  $i$  in the tree represents a cluster at level  $i$  in the regular multilevel partition.
2. A vertex at level  $i > 0$  has children that represent the clusters at level  $i - 1$  whose union is the cluster it represents.

The height of a topology tree is logarithmic in the number of regular vertices in the leaves [2].

We also store adjacency information for the clusters. Two regular clusters  $C$  and  $C'$  at level 0 are *adjacent*, if there exists a vertex  $v \in C$  and a vertex  $w \in C'$  such that  $v$  and  $w$  are adjacent in  $G$ .

We call two clusters  $C$  and  $C'$  at level  $i$  adjacent, if they have adjacent children. A regular cluster  $C$  at level 0 is adjacent to a singular vertex  $s$  if there exists a regular vertex  $v \in C$  adjacent to  $s$ . A cluster at level  $i > 0$  is adjacent to a singular vertex  $s$  if it has a child adjacent to  $s$ .

### 4.2 Maintaining a regular multilevel partition

The following procedure, for maintaining a regular multilevel partition under edge insertions, closely follows the procedure described in [2], as our data structure is a direct adaptation of Frederickson's.

**Level 0:** It is very easy to adjust the regular partition, i.e., the regular clusters at level 0 of the regular multilevel partition. When an edge  $e = \{x, y\}$  is inserted, we distinguish

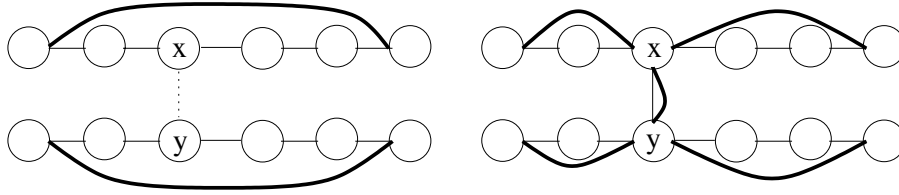

Figure 1: Case 6 of edge insertions described in Section 3.

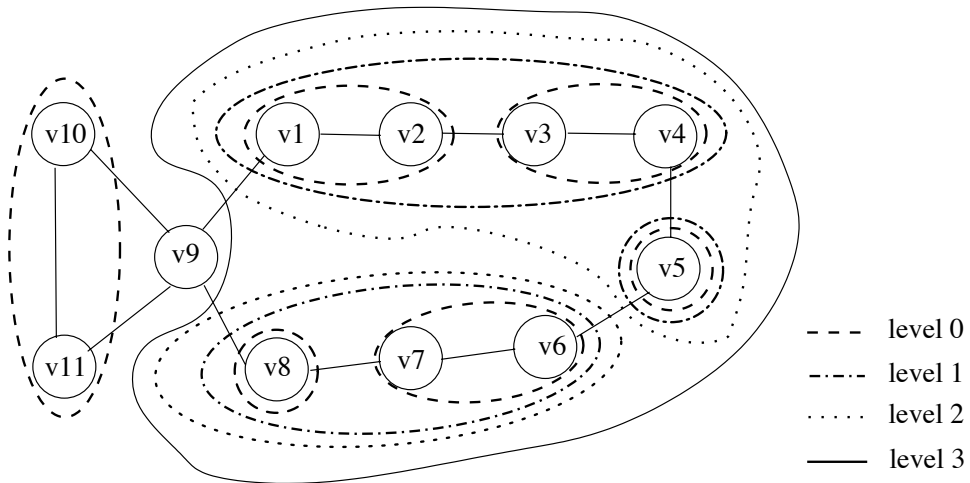

Figure 2: Example of a regular multilevel partition of a graph.

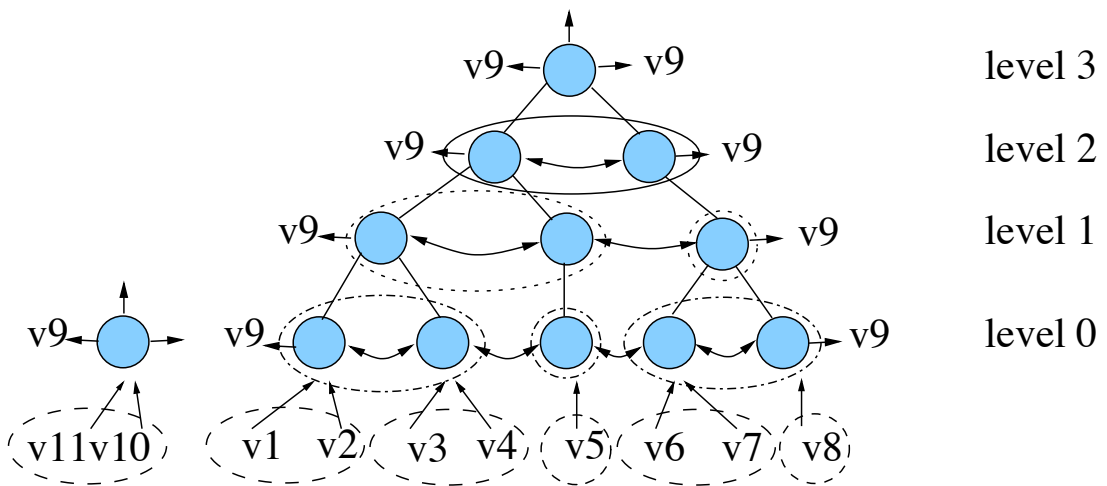
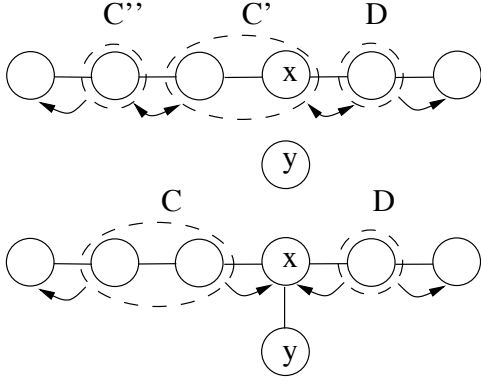

Figure 3: The regular forest corresponding to the regular multilevel partition shown in Figure 2.



**Figure 4: Adjusting the regular partition after inserting edge  $\{x, y\}$ .**

between the following cases: 1. the edge  $e$  destroys a regular vertex  $u$ ; 2. the edge  $e$  destroys two regular vertices  $u$  and  $v$ ; 3. the edge  $e$  creates a regular vertex  $u$ ; 4. the edges  $e$  creates two regular vertices  $u$  and  $v$ ; 5. the edge  $e$  does not change the number of regular vertices. We denote with  $C_u$  ( $C_v$ ) the regular cluster containing the vertex  $u$  ( $v$ ). We treat these cases as follows.

1. If the size of  $C_u$  is 1, then this cluster is deleted. Otherwise if  $C_u$  is adjacent to a cluster  $C$  of size one, remove  $u$  from  $C_u$  and union  $C_u$  with  $C$ .
2. Apply case 1 to both  $C_u$  and  $C_v$ .
3. Create a new cluster  $C_u$  only containing  $u$ . If  $C_u$  is adjacent to a cluster  $C$  of size one, union  $C_u$  with  $C$ .
4. Apply case 3, but if both  $C_u$  and  $C_v$  are not adjacent to a cluster of size one, then they are unioned together.
5. Nothing has to be done.

As an example consider the graph depicted in Figure 4. The insertion of edge  $\{x, y\}$  destroys the regular vertex  $x$ , so we are in case 1. Because  $C'$  is adjacent to  $C''$  and the size of  $C''$  is one, we must union  $C'$  and  $C''$  together into a new regular cluster  $C$ . The maintenance of the regular partition is completed after adjusting the adjacency information of both  $C$  and  $D$ , as shown in Figure 4.

**Level  $> 0$ :** We assume the regular partition at level 0 reflects the insertion of an edge, as discussed above. The number of clusters which have changed, inserted or deleted is at most some constant. We put these clusters in a list  $L_C$ ,  $L_I$ , and  $L_D$  according to whether they are changed, inserted or deleted. More specifically, these lists are initialized as follows. Each regular cluster that has been split or combined to form a new regular cluster is inserted in  $L_D$ , while each new regular cluster is inserted in list  $L_I$ . The adjacency information is stored with the clusters in  $L_I$ . For clusters in  $L_D$  every adjacency information is set to null, except the parent information. For each regular cluster whose set of vertices has not changed but its adjacency information has changed, update the adjacency information and insert it into  $L_C$ .

We create lists  $L'_D$ ,  $L'_I$ , and  $L'_C$  to hold the clusters at the next higher level of the regular multilevel partition. These lists are initially empty.

We first adjust the clusters in the list  $L_D$ . Every cluster  $C$  in  $L_D$  is removed from  $L_D$ , and  $C$  is removed as child from its parent  $\mathcal{P}$  (if existing).

- If  $\mathcal{P}$  has no more children, then insert  $\mathcal{P}$  in  $L'_D$ .
- If  $\mathcal{P}$  still has a child  $C'$ , then if  $C'$  is not already in  $L_C$  or  $L_D$ , then insert  $C'$  into  $L_C$ .

Next, we search the list  $L_C$  for clusters that have siblings. Suppose that  $C \in L_C$  has a sibling  $C'$  and parent  $\mathcal{P}$ .

- If  $C$  and  $C'$  are adjacent, then remove  $C$  from the list  $L_C$ , and remove  $C'$  from  $L_C$  if it is in this list. Insert  $\mathcal{P}$  into  $L'_C$ .
- If  $C$  and  $C'$  are not adjacent, then remove  $C$  and  $C'$  as children from  $\mathcal{P}$ . Remove  $C$  from the list  $L_C$ , and also remove  $C'$  from  $L_C$  if it is in this list. Insert both  $C$  and  $C'$  into  $L_I$ , and insert  $\mathcal{P}$  in  $L'_D$ .

Finally, we treat any remaining cluster  $C$  in  $L_C$  and  $L_I$ . First remove  $C$  from the appropriate list. Then in what follows the degree of  $C$  is the number of adjacent clusters.

- If  $C$  has degree zero, then it is the root of a tree in the regular forest. Insert its parent  $\mathcal{P}$ , if existing, in  $L'_D$ .
- If  $C$  has degree one or two, then we have the following possibilities:
  - If every adjacent cluster to  $C$  has a sibling, then insert the parent  $\mathcal{P}$  of  $C$  into  $L'_C$  in case  $\mathcal{P}$  exists. In case  $C$  does not have a parent, create a new parent cluster  $\mathcal{P}$  and insert it into  $L'_I$ .
  - Let  $C'$  be a cluster adjacent to  $C$  which has no sibling. Remove  $C'$  from the appropriate list, if it is in a list. If both  $C$  and  $C'$  have a parent, denoted by  $\mathcal{P}$  and  $\mathcal{P}'$  respectively, then remove  $C$  as child of  $\mathcal{P}$  and make it a child of  $\mathcal{P}'$ . Insert  $\mathcal{P}$  into  $L'_D$ , and insert  $\mathcal{P}'$  into  $L'_C$ . If both  $C$  and  $C'$  have no parent, then create a new parent  $\mathcal{P}$  of  $C$  and  $C'$ , and insert  $\mathcal{P}$  into  $L'_I$ . If  $C$  has a parent  $\mathcal{P}$ , and  $C'$  has no parent, then make  $C'$  a child of  $\mathcal{P}$  and insert  $\mathcal{P}$  into  $L'_C$ . The case that  $C'$  has a parent  $\mathcal{P}'$ , and  $C$  has no parent, is analogous.

When all clusters are removed from  $L_D$ ,  $L_C$ , and  $L_I$ , determine and adjust the adjacency information for all clusters in  $L'_D$ ,  $L'_C$ , and  $L'_I$  and reset  $L_C$  to be  $L'_C$ ,  $L_C$  to be  $L'_C$ , and  $L_I$  to be  $L'_I$ . If no clusters are present in  $L'_D$ ,  $L'_C$  or  $L'_I$ , nothing needs to be done and the iteration stops. This completes the description of handling lists  $L_D$ ,  $L_C$ , and  $L_I$ .

### 4.3 Finding a topological edge

Consider that we are in one of the cases 4–6 described in Section 3, where we have to split a topological edge. Let  $x$  be the regular vertex at which we have to split the topological edge. We store a pointer from  $x$  to the regular cluster  $C_x$  in which it is contained. We also store a pointer from each root of a tree  $T$  in the regular forest to the topological edge, corresponding to the regular path formed by all vertices in the leaves of  $T$ . We find the topological edge which needs to be split by going from  $C_x$  to the root of the tree containing  $C_x$ . Since the height of the tree is at most  $O(\log \ell)$ , where  $\ell$  is the current number of edge insertions, we obtain the following.

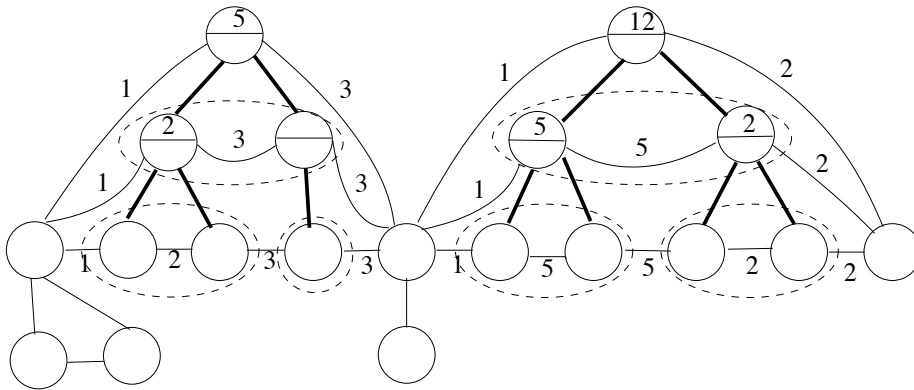

Figure 5: Example of a regular tree together with its weight information.

PROPOSITION 4.1. *Given a regular vertex  $x$ , the regular forest returns the topological edge corresponding to the regular path on which this regular vertex lies in  $O(\log \ell)$  time.*

#### 4.4 Storing weight information

We store weight information in two different places. We define the weight of a regular cluster at level 0 of size one as zero. Let  $\mathcal{C}$  be a cluster at level 0 of size two, and let  $v$  and  $w$  be the two regular vertices in  $\mathcal{C}$ . Then we define the weight of  $\mathcal{C}$  as the weight of the edge  $\{v, w\}$ . If a cluster at level 0 is adjacent to a singular vertex  $s$ , then we store the weight of  $\{v, s\}$  together with the adjacency information (here,  $v$  is the vertex in  $\mathcal{C}$  adjacent to  $s$ ). If two clusters  $\mathcal{C}$  and  $\mathcal{C}'$  at level 0 are adjacent, then we store the weight of  $\{v, w\}$  together with their adjacency information (here  $v \in \mathcal{C}$  and  $w \in \mathcal{C}'$  and  $v$  is adjacent to  $w$ ).

The weight of a cluster of size one at level  $i > 0$ , is defined as the weight of its child at the next lower level. The weight of a cluster of size two at level  $i > 0$  equals the sum of the weights of its two children and the weight stored with their adjacency information. If two clusters at level  $i > 0$  are adjacent, we store the weight of the adjacency information of their adjacent children. If a cluster at level  $i > 0$  is adjacent to a singular node, we store the weight of the adjacency information of its child and the singular node.

#### 4.5 Maintaining weight information

The weight of clusters and the weights stored together with the adjacency information, is updated after each run of the update procedure for the regular multilevel partition, with an extra constant cost. Indeed, both the weights of clusters at level 0 and the weights stored with the adjacency information, are trivially updated. When we assume that all levels lower than  $i$  represent the weight information correctly, the weight information of clusters in  $L_C$  and  $L_I$  is trivially updated using the weight information at level  $i - 1$ .

#### 4.6 Finding the weights

As mentioned above, each root of a regular tree in the regular forest, has a pointer to a unique topological edge. This root has its own weight, as defined above, and is adjacent to two singular vertices. The weight of the topological edge is obtained by summing the weight of the root together with the weights of the adjacency information of the two singular vertices. This is illustrated in Figure 5.

#### 4.7 Complexity Analysis

The complexity of the Topology Tree Algorithm is governed by two things: the maximal height of a single tree in the regular forest, and the amount of work that needs to be done at each level in the maintenance of the regular multilevel partition. We already saw that the height of a single tree is logarithmic in the number of regular vertices on the regular path on which the tree is built. Moreover, Frederickson has proven that in the lists  $L_C$ ,  $L_D$ , and  $L_I$  only a constant number of clusters are stored [2]. These lists are updated at most  $O(\log \ell)$  times, where  $\ell$  is the number of edge insertions, so that the total update time is  $O(\log \ell)$  per edge insertion. Hence, we may conclude the following:

THEOREM 4.1. *The total time spent on  $\ell$  updates by the Topology Tree Algorithm is  $O(\ell \log \ell)$ .*

### 5. Renumbering Algorithm

In this section we introduce another algorithm for keeping the simplification of a graph up-to-date when this graph is subject to edge insertions. We first show how the topological edges can be found efficiently.

#### 5.1 Assigning numbers to the regular vertices

We number the regular vertices, that lie on a regular path, consecutively. The numbers of the regular vertices on any regular path will always form an interval of the natural numbers. The Renumbering Algorithm will maintain two properties:

**Interval property:** the assignment of *consecutive* numbers to *consecutive* regular points;

**Disjointness property:** *different* regular paths have *disjoint* intervals.

We then have a unique interval associated with each regular path, and hence with each topological edge of size  $> 0$ . Moreover, we choose the minimum of such an interval as a unique number associated with a topological edge. Specifically, the minimal number serves as a *key* in a *dictionary*. Recall that in general, a dictionary consists of pairs  $\langle \text{key}, \text{item} \rangle$ , where the item is unique for each key. Given a number  $k$ , the function which returns the item with the maximal key smaller than  $k$  can be implemented in  $O(\log N)$  time, where  $N$  is the number of items in the dictionary [1].

The items we use contain the following information.

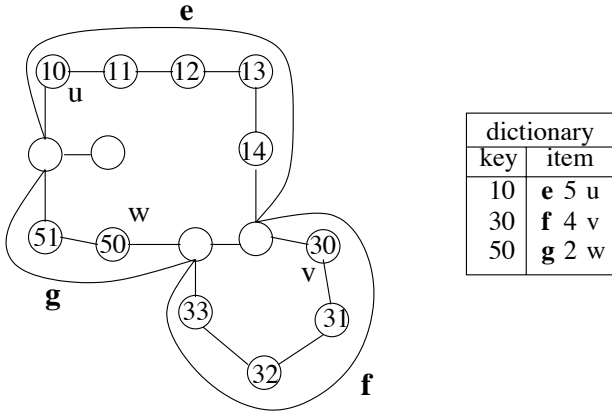

Figure 6: Dictionary example.

1. An identifier of the topological edge associated with the key.
2. The number of regular vertices on the regular path corresponding to this topological edge.
3. An identifier of the regular vertex that has the key as number on this path.

In Figure 6 we give an example of a dictionary containing three keys, corresponding to the three topological edges in the simplification  $G_s$  of the graph  $G$ .

### 5.2 Maintaining the number of the regular vertices

We must now show how to maintain this numbering under updates, such that the interval and disjointness properties mentioned above remain satisfied. Actually, only in case 3 in Section 3 we need to do some maintenance work on the numbering. Indeed, by merging two topological edges, the numbering of the regular vertices is no longer necessarily consecutive. We resolve this by *renumbering* the vertices on the shorter of the two regular paths. Note that the size of a regular path is stored in the dictionary item for that path.

To keep the intervals disjoint, we must assume the maximal number of edge insertions to which we need to respond is known in advance. Concretely, let us assume that we have to react to at most  $\ell$  update operations. This assumption is rather harmless. Indeed, one can set this maximum limit to a large number. If it is eventually reached, we restart from scratch. A regular path is “born” with at most two regular vertices on it. Every time a new regular path is created, say the  $k$ th time, we assign the number  $2k\ell$  to one of the two regular vertices on it. Hence, newly created topological edges correspond to numbers which are  $2\ell$  apart from each other. Since a newly created topological edge can become at most  $\ell - 1$  vertices longer, no interference is possible.

### 5.3 Finding the topological edge

Consider that we are in one of the cases 4–6 described in Section 3, where we have to split the topological edge at vertex  $x$ . We look at the number of  $x$ , say  $k$ , and find in the dictionary the item associated with the maximal key smaller than  $k$ . This key corresponds to the interval to which  $k$  belongs, or equivalently, to the regular path to which  $x$  belongs. In this way we find the topological edge which has to be split, since this edge is identified in the returned item.

The numbering thus enables us to find an edge in  $O(\log m')$  time, where  $m'$  is the number of edges in  $G_s$  which correspond to a regular path passing through at least one regular vertex. Since  $m' \leq m$ , the number of edges in  $G$ , we obtain:

PROPOSITION 5.1. *Given a regular vertex and its number, the dictionary returns in  $O(\log m)$  time the topological edge corresponding to the regular path on which it lies.*

We next show how, when a topological edge is split, we can quickly find the weights of the two new edges created by the split.

### 5.4 Assigning weights to the regular vertices

The *weight* of a regular vertex  $v$  will be denoted by  $\lambda^*(v)$ . Weights will be assigned to the regular vertices such that if  $v$  and  $w$  are two consecutive regular vertices with weights  $\lambda^*(v)$  and  $\lambda^*(w)$  respectively, then  $\lambda(\{v, w\}) = |\lambda^*(v) - \lambda^*(w)|$ .

### 5.5 Maintaining weights of regular vertices

The maintenance of the weights of regular vertices under edge insertions is easy. It requires only constant time when a topological edge is extended. Indeed, let  $\{x, y\}$  be a topological edge, and suppose that we extend this edge by inserting  $\{y, z\}$ . Let  $u$  be the regular vertex adjacent to  $y$ . Then,

- if  $\lambda^*(u) < 0$ , then  $\lambda^*(y) := \lambda^*(u) - \lambda(\{u, y\})$ .
- if  $\lambda^*(u) \geq 0$ , and no regular vertex with a positive weight is adjacent to  $u$ , then  $\lambda^*(y) := \lambda^*(u) + \lambda(\{u, y\})$ . Otherwise, let  $v$  be the regular vertex adjacent to  $u$ . If  $\lambda^*(v) > \lambda^*(u)$ , then let  $\lambda^*(y) = \lambda^*(u) - \lambda(\{u, y\})$ , else let  $\lambda^*(y) = \lambda^*(u) + \lambda(\{u, y\})$ .

When a topological edge is split, no adjustments to the weight of the remaining regular vertices is needed at all. However, when two topological edges are merged we need to adjust the weights of the regular vertices on the shortest of the two regular paths, as shown in Figure 7. This adjustment of the weights can clearly be done simultaneously with the renumbering of the vertices.

### 5.6 Finding the weights

The weights of regular vertices now enable us to find the weights of the two edges created by a split of a topological edge in logarithmic time. Indeed, given the number of the regular vertex where the split occurs, we search in the dictionary which topological edge needs to be split; call it  $\{z_1, z_2\}$ . In the returned item we find the vertex which has the minimal number of the vertices on the regular path corresponding to  $\{z_1, z_2\}$ . Denote this vertex with  $u$  which is adjacent to either  $z_1$  or  $z_2$ . We assume that  $u$  is adjacent to  $z_1$ , the other case being analogous. The weights of the new topological edges  $\{z_1, x\}$  and  $\{x, z_2\}$  can be computed by:

- $\lambda(\{z_1, x\}) := \lambda(\{z_1, u\}) + |\lambda^*(u) - \lambda^*(x)|$ ; and
- $\lambda(\{x, z_2\}) := \lambda(\{z_1, z_2\}) - \lambda(\{z_1, x\})$ .

If only one regular vertex remains on a regular path after a split, or a regular vertex becomes singular, then the weight of this vertex is set to 0. This can all be done in constant time, after the topological edge which needs to be split has been looked up in the dictionary.

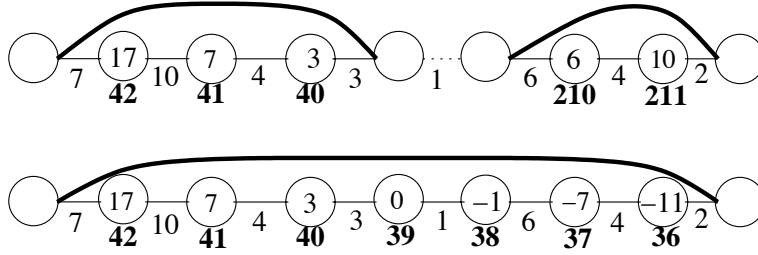

Figure 7: Assigning new numbers and weights of regular vertices simultaneously when two topological edges are merged. The numbers of regular vertices are in bold, the weights are inside the vertices.

### 5.7 Complexity analysis

By the *amortized complexity* of an on-line algorithm [13, 8], we mean the total computational complexity of supporting  $\ell$  updates (starting from the empty graph), as a function of  $\ell$ , divided by  $\ell$  to get the average time spent on supporting one single update. We will prove here that the Renumbering Algorithm has  $O(\log \ell)$  amortized time complexity. We only count edge insertions because the insertion of an isolated vertex has zero cost.

**THEOREM 5.1.** *The total time spent on  $\ell$  updates by the Renumbering Algorithm is  $O(\ell \log \ell)$ .*

To conclude this section, we recall from Section 5.2 that the maximal number assigned to a regular vertex is  $2\ell^2$ . So, all numbers involved in the Renumbering Algorithm take only  $O(\log \ell)$  bits in memory. Theorem 5.1 assumes the standard RAM computation model with unit costs. If logarithmic costs are desired, the total time is  $O(\ell \log^2 \ell)$ .

## 6. Experimental Comparison

The Renumbering Algorithm and the Topology Tree Algorithm are very different, but have the same theoretical complexity. Hence, the question arises how they compare experimentally. In this section we try to obtain some insight into this question.

Both algorithms were implemented in C++ using LEDA [9]. We used the GNU g++ compiler version 2.95.2 without any optimization option. Our experiments were performed on a SUN Ultra 10 running at 440 Mhz with 512 MB internal memory. Implementing the Renumbering algorithm was considerably easier than implementing the Topology Tree Algorithm.

We conducted our experiments on three types of inputs. First of all, we extensively studied random inputs, which are random sequences of updates on random graphs. Next, we used two kinds of non-random graph inputs which focus specifically on the merging and the splitting of topological edges. Hence, we construct an input sequence which repeatedly merges topological edges, and an input sequence which first creates a very large number of small topological edges and then splits these edges randomly. Finally, we ran both algorithms on two inputs originating from real data sets.

**Methodology:** Since the experiments have an element of randomness, we show the results in the form of 95% confidence intervals. For each test, we perform a large number of runs. For each run, we compute the ratio between the total time taken by Topology Tree and that taken by Renumbering. We took the average of these ratios and computed

vertices \ edges	m=5 000	m=10 000	m=20 000
n=1 000	[1.10, 1.15]	[1.03, 1.06]	[0.97, 0.99]
vertices \ edges	m=5 000	m=25 000	m=75 000
n=5000	[1.25, 1.29]	[1.01, 1.03]	[0.96, 0.98]
vertices \ edges	m=10 000	m=50 000	m=150 000
n=50 000	[1.30, 1.35]	[1.06, 1.07]	[0.91, 0.92]
vertices \ edges	m=10 000	m=100 000	m=300 000
n=100 000	[1.21, 1.23]	[0.98, 0.99]	[0.85, 0.86]

Table 1: 95% confidence intervals on ratio between Topology Tree and Renumbering, from 1000 runs on random inputs.

the 95% confidence interval. So, for example, the interval [1.10, 1.15] means that Topology Tree was 10 to 15% slower than Renumbering in 95% of the runs in the test.

**Random Inputs:** The random inputs consist of random graphs that are generated, given the number of vertices and edges. Each run builds a random graph incrementally with the insertions uniformly distributed over the set of edges. We conducted a series of tests for different number of nodes  $n$  and number of edges  $m$ . For every pair of values for  $n$  and  $m$  we did 1000 runs. The results of these experiments are shown in Table 1.

For small numbers of edge insertions, i.e., when the probability of having many regular vertices is large, we see that the Renumbering Algorithm is faster. However, when the number of edge insertions increases, the Topology Tree Algorithm becomes slightly faster. This is probably due to the fact that the dictionary in the Renumbering Algorithm becomes very large, i.e., there are many short topological edges, and hence it takes longer to search for topological edges.

**Non-Random Inputs:** The non-random inputs consisted of two types. For the first type, we created a large number of topological edges and then started to merge these edges pairwise. The end result was a very long topological edge. For the second type, we first created a very large number of short regular paths consisting of a single regular vertex, and then started to split these randomly. Each result shown in Table 2 is obtained from 100 runs.

The first type of input was designed in order to reproduce the cases, observed in the random inputs, where Renumbering is much faster than Topology Tree. This is confirmed by the experimental result. Indeed, on this type of inputs, the Topology Tree Algorithm has to maintain large topology

Merge ( $n = 20\,099$ , $m = 20\,098$ )	[3.60, 3.74]
Split ( $n = 280\,000$ , $m = 200\,000$ )	[1.15, 1.17]

**Table 2: 95% confidence intervals on ratio between Topology Tree and Renumbering, from 100 runs on non-random inputs.**

Hydrography	[1.62, 1.66]
Railroad	[0.95, 0.96]

**Table 3: 95% confidence intervals on ratio between Topology Tree and Renumbering, from 100 runs on real datasets.**

trees, which is probably the reason that it is slower.

The second type of input was designed in an attempt to reproduce the cases where Topology Tree is faster than Renumbering. Our attempt failed, however, as the experimental result does not confirm this. Indeed, although the topology trees all have height one, while the dictionary is very large, the Renumbering Algorithm nevertheless still is faster.

**Real Data Inputs:** We also tested the relative performance of both algorithms with respect to graphs representing real data. We present the results on two data sets:

**Hydrography graph** A data set representing the hydrography of Nebraska. This set contains 157 972 vertices, of which 96 636 are regular.

**Railroad graph** A data set representing all railway mainlines, railroad yards, and major sidings in the continental U.S. compiled at a scale 1 : 100 000. It contains 133 752 vertices of which only 14 261 are regular. It is available at the U.S. Bureau of Transportation Statistics ([www.bts.gov/gis](http://www.bts.gov/gis)).

The results shown in Table 3 are obtained after performing 100 experiments. In each experiment, we ran both algorithms in a random way on these data sets. We computed the ratio between the total time the Topology Tree Algorithm needed to perform the test and the total time the Renumbering Algorithm needed to accomplish the same task. We took the average of this ratio and computed the 95% confidence interval. Again, we see that when there are only few, but long, topological edges, the Renumbering Algorithm is faster than the Topology Tree Algorithm. When there are many, short, topological edges, like in the railroad graph, the Topology Tree Algorithm is slightly faster than the Renumbering Algorithm.

In summary, our experimental study shows that when the percentage of regular vertices is high in a graph, then the Renumbering Algorithm is clearly better than the Topological Tree Algorithm, and when the same percentage is low, then the reverse often holds. However, our experimental study did not compare any specific problem solving with and without using topological simplification. Intuitively, the value of topological simplification should increase with the percentage of regular vertices in the graph. Therefore, when the percentage of the regular vertices is high, the Renumber-

ing Algorithm should be not only better than the Topological Tree Algorithm but also yield a significant time saving over problem solving without topological simplification. We expect this to be the most important practical implication of our study for the case when there are only insertions of edges and vertices into the graph. However, when a fully dynamic structure is needed, then the Topological Tree Algorithm should be also advantageous in practice.

## Acknowledgement

We would like to thank Bill Waltman for providing us with the hydrography data set.

## 7. References

- [1] T.H. Cormen, C.E. Leieron, and R.L. Rivest. *Introduction to Algorithms*. MIT Press, 2001.
- [2] G.N. Frederickson. Data structures for on-line updating of minimal spanning trees. *SIAM J. Comput.*, Vol 14:781–798, 1985.
- [3] G.N. Frederickson. Ambivalent data structures for dynamic 2-edge-connectivity and  $k$  smallest spanning trees. *SIAM J. Comput.*, Vol 26(2):484–538, 1997.
- [4] F. Geerts, B. Kuijpers, and J. Van den Bussche. Topological canonization of planar spatial data and its incremental maintenance. In T. Polle, T. Ripke, and K.-D. Schewe, editors, *Fundamentals of Information Systems*, Kluwer Academic Publishers, 1998, pp 55–68.
- [5] F. Geerts, P. Revesz, and J. Van den Bussche. On-line topological simplification of weighted graphs. Technical report, arXiv:cs.DS/0608091. <http://arxiv.org/abs/cs.DS/0608091>
- [6] G. Italiano. Dynamic graph algorithms. In Mikhail J. Atallah, editor, *Handbook on Algorithms and Theory of Computation*, CRC Press, 1998.
- [7] B. Kuijpers, J. Paredaens, and J. Van den Bussche. Lossless representation of topological spatial data. In: *Advances in Spacial Databases*, Volume 951 of Lecture Notes in Computer Science, pages 1–13, Springer-Verlag, 1995.
- [8] K. Mehlhorn. *Data Structures and Algorithms 1: Sorting and Searching*. EACTS Monographs on Theoretical Computer Science. Springer-Verlag, 1984.
- [9] K. Mehlhorn and S. Näher. LEDA: A platform for combinatorial and geometric computing. *Comm. of the ACM*, Vol 38(1):96–102, 1995.
- [10] C.H. Papadimitriou, D. Suciu, and V. Vianu. Topological queries in spatial databases. *Journal of Computer and System Sciences*, Vol 58(1):29–53,1999.
- [11] L. Segoufin and V. Vianu. Querying spatial databases via topological invariants. *Journal of Computer and System Sciences*, Vol 61(2):270–301, 2000.
- [12] R. Tamassia On-line planar graph embedding. *Journal of Algorithms*, Vol 21:201–239, 1996.
- [13] R.E. Tarjan. Data structures and network algorithms. In CBMS-NSF Regional Conference Series in Applied Mathematics, Vol 44. SIAM, 1983.
- [14] M.F. Worboys, and M. Duckham. *GIS: A Computing Perspective*. Taylor&Francis, second edition 2004.